

QCDml: Update Proposals



ILDG10 (May.18,2007)

T. Yoshie for MDWG CCS,Tsukuba



- naming namespaces **concluded**
- link smearing **almost completed**
- anisotropic actions **almost completed**
- **issue of unique markup**

Naming Namespaces

- discussed at ILDG7, raised again at ILDG9
- how to treat namespaces when non-backward compatible change was made to schema
 - at ILDG9, <normalisation> element for six-link actions was added to **ensemble1.3**
 - new one is not-backward compatible
- three options
 - do not change ensemble namespace
 - no version control, be thrown into confusion
 - only affected ensembles live in a new namespace
 - Middleware has to support multiple namespaces
 - all ensembles live in a new namespace
 - have to rewrite all ensemble XML documents

- Suggestion from MWWG
 - multiple namespaces are difficult to deal with, both theoretically and practically
 - use only one unique namespace at a time
 - update of XML documents has to be made in some synchronized way across ILDG sites
- WG conclusion: all live in new namespace
 - count-up namespace version number to
<http://www.lqcd.org/ildg/QCDml/ensemble1.4>
<http://www.lqcd.org/ildg/QCDml/ensemble1.4/QCDmlEnsemble1.4.0.xsd>
- when we start upgrade
 - will be decided by the MWWG
 - after ensemble1.4 is completed by the MDWG

- **Configuration Namespace**

- two options:

- A) live in a new namespace config1.4

- B) keep namespace unchanged

- propose B) **keep config namespace unchanged**

- configuration schemata is unchanged

- huge number of config XML are stored in ILDG MDC and time consuming to rewrite all of them

<http://www.lqcd.org/ildg/QCDml/config1.3>

<http://www.lqcd.org/ildg/QCDml/ensemble1.3/QCDmlEnsemble1.3.0.xsd>

- **Note**

- schema files have three digits e.g. **1.4.0**

- first two digits (1.4) for **version number** corresponding to the name of namespace

- last digit (0) for **release number** (to distinguish compatible changes)

Update Proposals

- started to markup
 - link smearing
 - anisotropic actions
- meeting requirements of
 - FLIC action by CSSM
 - anisotropic gauge/clover quark with stout links by LHP Collab.
 - clover quark with stout links by QCDSF Collab.

Link Smearing

- General procedure of link smearing
 - blocking of link variables by APE, HYP

$$U_{\mu} \rightarrow (1 - \rho)U_{\mu} + \frac{\rho}{6} \sum_{\nu \neq \mu} (UUU + UUU)$$

- projection to SU(3) (unitarization) by stout, unit-circle, MaxReTr....
- repeat blocking and projection pair several times
- Necessary information
 - blocking type
 - blocking parameters
 - unitarization procedure
 - unitarization parameters if any
 - # of smearing steps

- implementation

```
<linkSmearing>  
  <APEBlocking>  
    <rho>0.22</rho>  
  </APEBlocking>  
  <StoutUnitarization>  
  </StoutUnitarization>  
  <numSmear>3</numSmear>  
</linkSmearing>
```

- support various blocking and unitarization procedures as substitutions
- `<linkSmearing>` is inserted as an optional element in general quark action
- affects all quark actions (see next page)
 - because all quark actions inherit properties from the general quark action

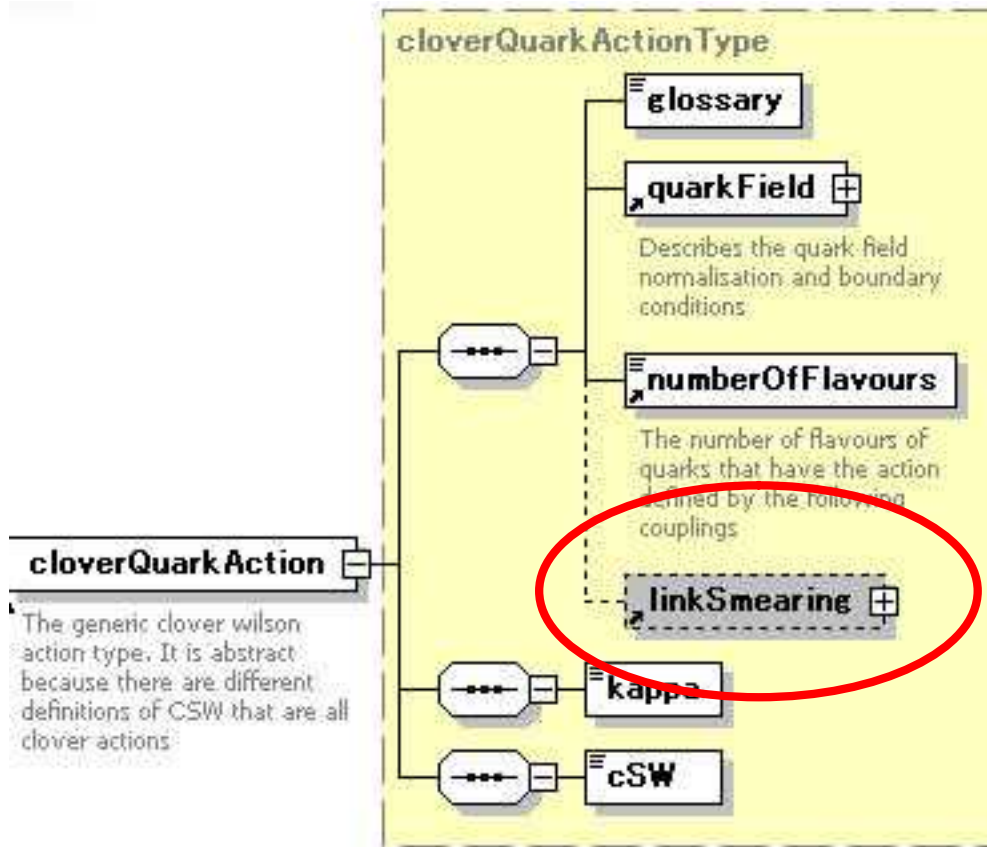

- makes it quite easy to implement FLIC quark action as an extension to clover quark action (with additional tadpole factors u_0 and u_{0fl})

Optional

<linkSmearing>
comes here

- still backward compatible (thin link action unchanged)
- design detail still under discussion
 - rather technical than strategic
- **ask you to leave this matter entirely to the MDWG** 8

Anisotropic Actions

- new inheritance tree for anisotropic actions
 - (general) anisotropic gluon action
 - anisotropic Wilson gluon action
 - anisotropic tadpole improved Wilson gluon action

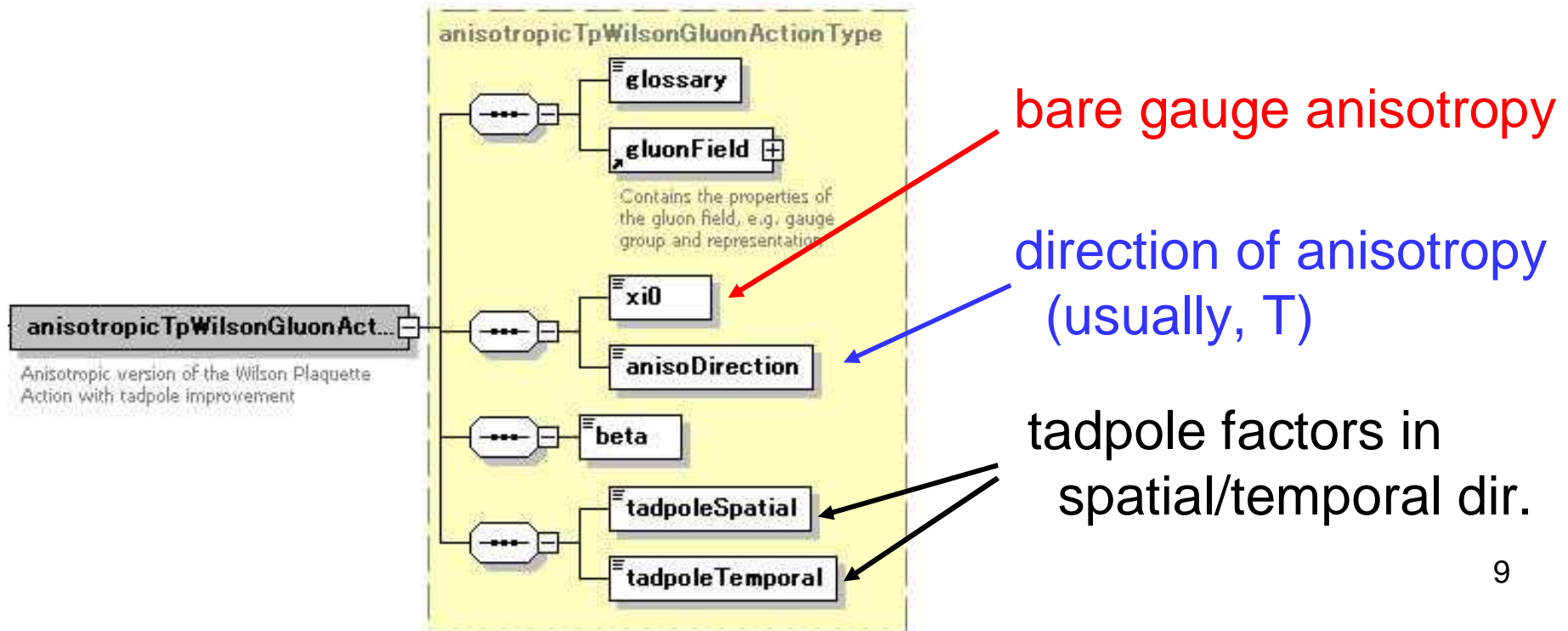

- gauge action notation is more or less standard
- wilson/clover quark action notation may not be
 - some groups prefer using kappa, others mass
 - the issue of unique markup
 - latent in isotropic actions
 - apart from the issue, marking up anisotropic quark action is not complicated

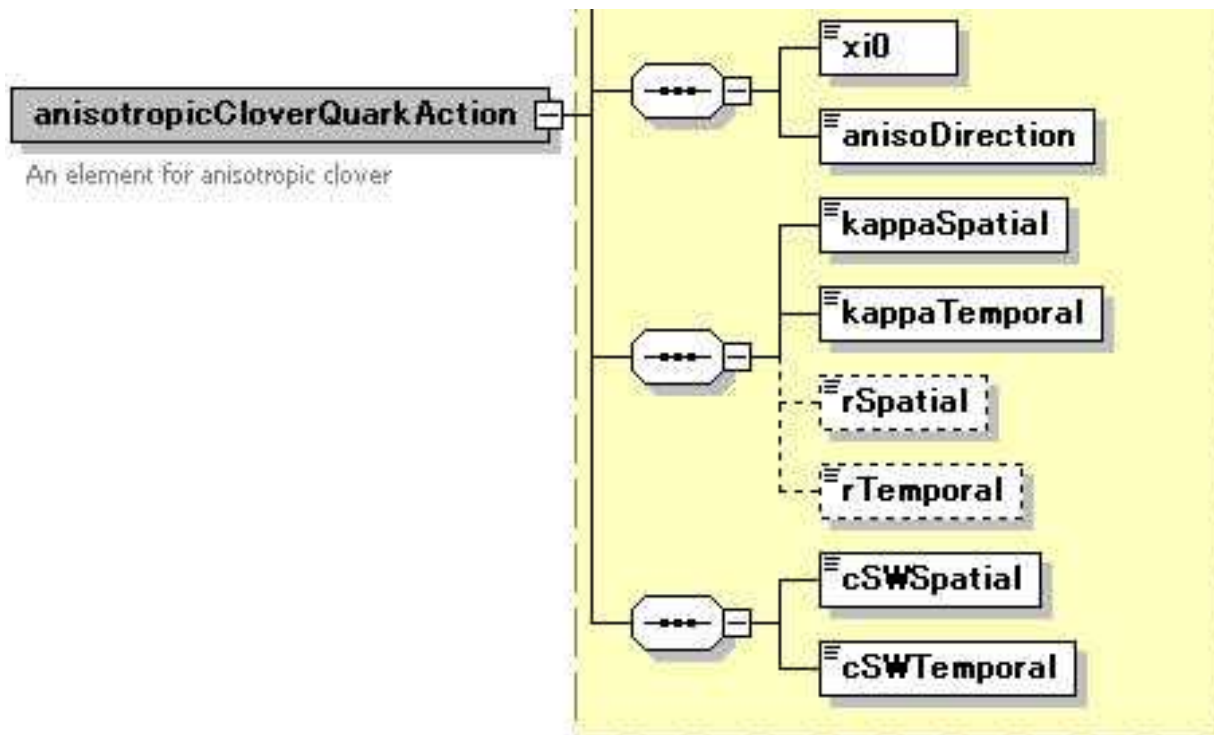

split kappa and cSW into two, those in spatial/temporal dir.

Wilson r parameters are optional (default=1.0)

- allowing both kappa and mass notations
 - easily implemented with <choice> element

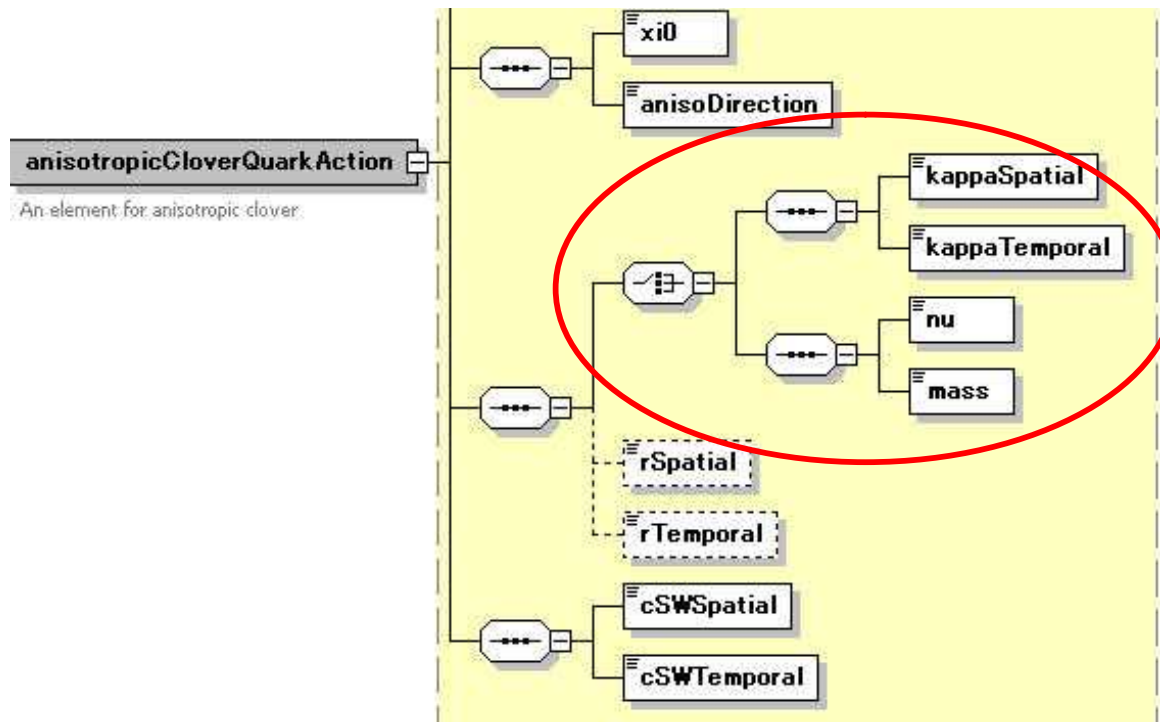

choose either
(kappaSpatial
kappaTemporal)
or
(nu,mass)

Issue of Unique Markup

- general and strategic issue
 - the issue is latent in any actions
 - though “kappa vs. mass” for Wilson-type actions is a typical example
 - the issue may reside also in link smearing
 - ILDG MDWG has so far tried to markup everything uniquely, taking particular notation (definition)....
 - kappa (not mass) for isotropic Wilson-type quark actions
 - recommended good normalization for each six-link action
 - whether or not (and to what extent) we change the “unique markup strategy” should be discussed beyond the level of MDWG

- discussion in MDWG
 - proposed to use mass notation (at least for anisotropic)
 - the notation is already used by some groups
 - proposed to use kappa notation
 - the notation is already used by some other groups
 - the kappa notation is already employed for isotropic actions
 - **compromise to allow several standards**
 - marking up couplings as they appear in literatures (in production code) benefits users to search (markup) ensembles
 - though all of us agree with importance of unique markup
 - **should aim at a unique markup**
 - it is one of the principal goals of ILDG

- MDWG consensus
 - consider **a unique markup to be a fundamental design strategy** for QCDml
 - but may consider **exceptions necessary if several standards are ALREADY used by big players** of the community
 - consider the case of anisotropic Wilson-type actions as an exceptional case
 - allow both kappa and mass notation
- **ask you to approve ensemble 1.4.1 (including further possible minor changes)**
 - we can narrowly escape the issue at present

Discussion for future

- To what extent do we have to support existing notations ?
 - as per community demand
 - non-unique markup should be exceptional
 - want to avoid unprincipled requests
- Do we have to be pro-active in proposing standard notations.....?
 - yes, to avoid confusion and encourage standards
 - no, it is not within the remit of WG to step into physics
- MDWG needs some guiding principles
 - please write opinions to us (regional grid WG member)

Summary and Concluding Remarks

- Top priority is to complete QCDml ensemble schemata 1.4.1
- Discussions should be made on whether and how we allow different conventions for one action/one smearing
- Lattice actions we markup are becoming more and more complicated
 - to avoid confusions, (human readable) documents including mathematical expressions and reference articles are mandatory
 - prepare documents for link smearing, anisotropic actions and possibly actions we have already marked up

Lattice 2007

- if you think it is a good idea,
- Poster presentation to announce
 - MDWG activity
 - what has been marked up
 - mathematical expressions for complicated actions and smearings
 - how to markup them
 -

MDWG member

G.Andronico (INFN)

P.Coddington (Adelaide)

C.DeTar (Utah)

R.Edwards (JLAB)

B.Joo (JLAB)

C.Maynard (Edinburgh)

D.Pleiter (NIC/DESY)

J.Simone (FNAL)

T.Yoshie (Tsukuba)

members involved in developing this version